

SB External Constant Section Rings for SAE Standard Bearings (Metric Sizes)

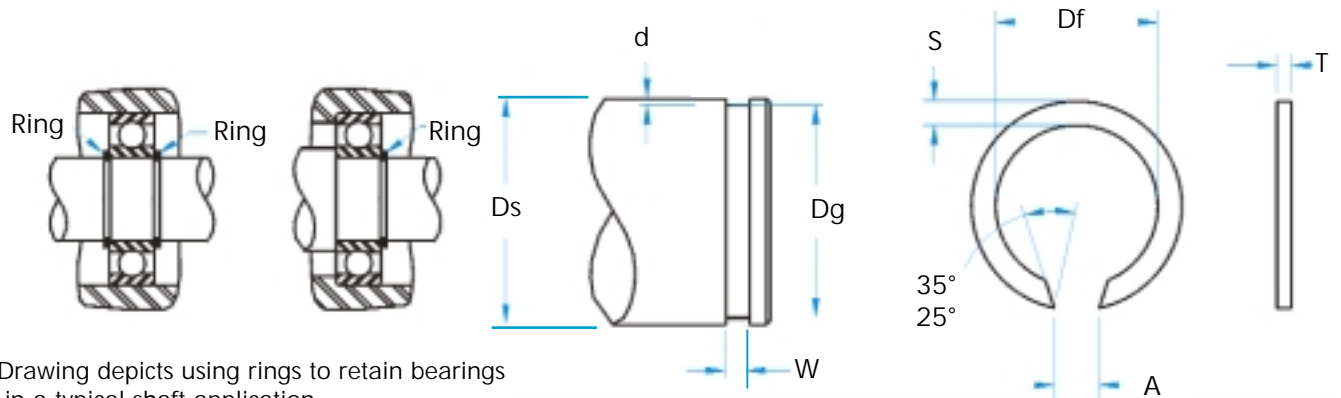

RING NUMBER	SHAFT DIAMETER		BEARING NUMBER			GROOVE DIAMETER			RING DIMENSIONS							
	Ds DEC	Ds mm				DIAMETER		DEPTH	FREE DIAMETER	THICKNESS	SECTION	FREE GAP				
						Dg	TOL.					W	d	Tol	T ± .002	S
SB-12	4724	12	201	301	—	.436	± .002	.046 + .003 - .000	.018	.421	+ .000 -	.042	.062 ± .003	.062	.187	
SB-15	5906	15	202	302	—	.550		.053	.020	.538	+ .000	.047	.078	.078	.218	
SB-17	6693	17	203	303	403	.629		+ .004 - .000	.020	.616	-.025	.047	± .003	.078	.218	
SB-20	7874	20	204	304	404	.731	± .004	.068	.028	.710	+ .000	.062	.093 ± .003	.078	.218	
SB-25	9843	25	205	305	405	.924		+ .004 - .000	.030	.910		-.031	.062	.109 ± .003	.156	.312
SB-30	1.1811	30	206	306	406	1.111		.085 + .004 - .000	.035	1.093			.075	.125 ± .005	.156	.312
SB-35	1.3780	35	207	307	407	1.288	± .006	.108	.045	1.265	+ .000		.093	.156	.250	.406
SB-40	1.5748	40	208	308	408	1.465		+ .005	.055	1.452		-.046	.093	± .005	.250	.406
SB-45	1.7717	45	209	309	409	1.648		-.000	.062	1.625		+ .000	.093	.188	.250	.468
SB-50	1.9685	50	210	310	410	1.844	± .006	.062	1.820	-062	.093		± .005	.250	.468	
SB-55	2.1654	55	211	311	411	2.015		.120	.075		1.995		+ .000	.109	.218	.250
SB-60	2.3622	60	212	312	412	2.212		+ .005 - .000	.075		2.187	+ .000		.109	± .005	.250
SB-65	2.5591	65	213	313	413	2.389	± .006	.085	2.359	+ .000	.125			.250	.250	.468
SB-70	2.7559	70	214	314	414	2.586		.085	2.556		-062		.125		± .005	.250
SB-75	2.9528	75	215	315	415	2.783		.139	.085			2.750	+ .000			.125
SB-80	3.1496	80	216	316	416	2.979	+ .006	.085	2.946	-078		.125		± .005		.250
SB-85	3.3465	85	217	317	417	3.176	-.000	.085	3.139		+ .000	.125			.312	.250
SB-90	3.5433	90	218	318	418	3.343	± .006	.100	3.308			-078	.125			± .005
SB-95	3.7402	95	219	319	419	3.540		.100	3.500	+ .000			.156	.312		
SB-100	3.9370	100	220	320	420	3.737		.174	.100		3.697		+ .000		.156	
SB-105	4.1339	105	221	321	421	3.934	+ .008	.100	3.888		-093	.156			.312	.312
SB-110	4.3307	110	222	322	422	4.131	-.000	.100	4.080			.156		.312		.687

Hardness: All Ring Sizes-HRC 42-52

For alternate cutoff styles, contact Rotor Clip Technical Sales at 1-800-557-6867 (E-mail: tech@rotorclip.com)