

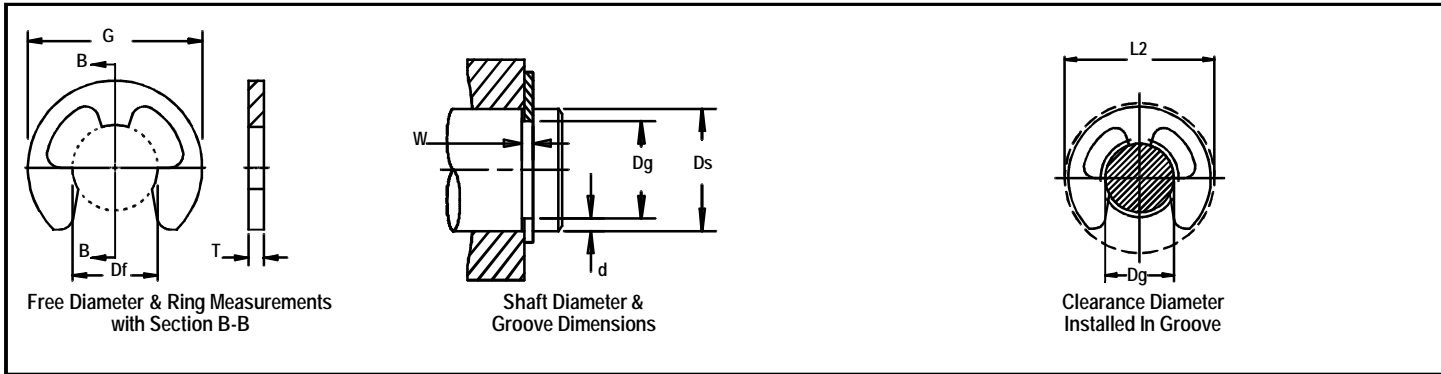

# Rotor Clip ME ANSI Metric Retaining Rings Radially Assembled, External Retaining Rings

The three prongs of this popular retaining ring make contact with the bottom of the groove, resulting in exceptional thrust loadings.



RING NO.	SHAFT DIAMETER		GROOVE SIZE						RING SIZE & WEIGHT				CLEARANCE		THRUST LD (kN)		
			DIAMETER		WIDTH		DEPTH		FREE DIAMETER		THICKNESS***		Free Out-Side Dia. Ref.	Re-leased In Groove	Sqr. Corner Abutment		
			Ds mm	Ds DEC	Dg	Tol.	F.I.M.**	W	Tol.	d	Df	Tol.			T	Tol.	kg
ME-1*	1	.039	0.72	-0.05	0.04	0.32	+0.05	0.14	0.64		0.25	±0.05	0.004	2.0	2.2	0.06	0.02
ME-2	2	.079	1.45		0.04	0.32		0.28	1.30		0.25		0.014	4.0	4.3	0.13	0.09
ME-3	3	.118	2.30		0.04	0.50	+0.10	0.35	2.10	+0.03	0.40		0.036	5.6	6.0	0.30	0.17
ME-4	4	.157	3.10	-0.08	0.05	0.70		0.45	2.90	-0.08	0.60		0.095	7.2	7.6	0.70	0.30
ME-5	5	.197	3.90		0.05	0.70		0.55	3.70		0.60		0.13	8.5	8.9	0.90	0.40
ME-6	6	.236	4.85		0.05	0.70		0.58	4.70		0.60		0.21	11.1	11.5	1.10	0.60
ME-7	7	.275	5.55		0.08	0.70		0.73	5.25		0.60		0.34	13.4	14.0	1.20	0.80
ME-8	8	.315	6.40		0.08	0.70		0.80	6.15		0.60		0.35	14.6	15.1	1.40	1.00
ME-9	9	.354	7.20	-0.10	0.08	1.00		0.90	6.80		0.90	±0.06	0.58	15.8	16.5	3.00	1.30
ME-10	10	.393	8.00		0.08	1.00	+0.15	1.00	7.60	+0.05	0.90		0.68	16.8	17.5	3.40	1.60
ME-11	11	.433	8.90		0.10	1.00		1.05	8.55	-0.10	0.90		0.68	17.4	18.0	3.70	1.90
ME-12	12	.472	9.60		0.10	1.20		1.20	9.20		1.10		1.00	18.6	19.3	4.90	2.30
ME-13	13	.512	10.30		0.10	1.20		1.35	9.95		1.10		1.13	20.3	21.0	5.40	2.90
ME-15	15	.591	11.80	-0.15	0.10	1.20		1.60	11.40		1.10		1.40	22.8	23.5	6.20	4.00
ME-16	16	.630	12.50		0.10	1.20		1.75	12.15		1.10		1.45	23.8	24.5	6.60	4.50
ME-18	18	.709	14.30		0.10	1.40		1.85	13.90	+0.10	1.30		2.3	27.2	27.9	8.70	5.40
ME-20	20	.787	16.00		0.10	1.40		2.00	15.60	-0.15	1.30		2.8	30.0	30.7	9.80	6.50
ME-22	22	.866	17.40	-0.20	0.10	1.40		2.30	17.00		1.30		3.4	33.0	33.7	10.80	8.10
ME-25	25	.984	20.00		0.10	1.40		2.50	19.50		1.30		4.2	37.1	37.9	12.20	10.10

\* AVAILABLE IN BERYLLIUM COPPER ONLY.

\*\* F.I.M. (FULL INDICATOR MOVEMENT)- MAXIMUM ALLOWABLE DEVIATION OF CONCENTRICITY BETWEEN GROOVE AND SHAFT.

† BASED ON GROOVES MADE OF COLD ROLLED STEEL. FOR AN EXPLANATION OF FORMULAS USED TO DERIVE THRUST LOAD AND OTHER PERFORMANCE DATA CONTACT THE ROTOR CLIP ENGINEERING DEPARTMENT.

\*\*\* FOR PLATED RINGS, ADD .002" TO THE LISTED MAXIMUM THICKNESS. MAXIMUM THICKNESS WILL BE A MINIMUM OF .0002" LESS THAN THE LISTED GROOVE WIDTH (W) MINIMUM.

For a technical concern,  
Please ask for our Technical Sales Department.

# 1-800-55-ROTOR

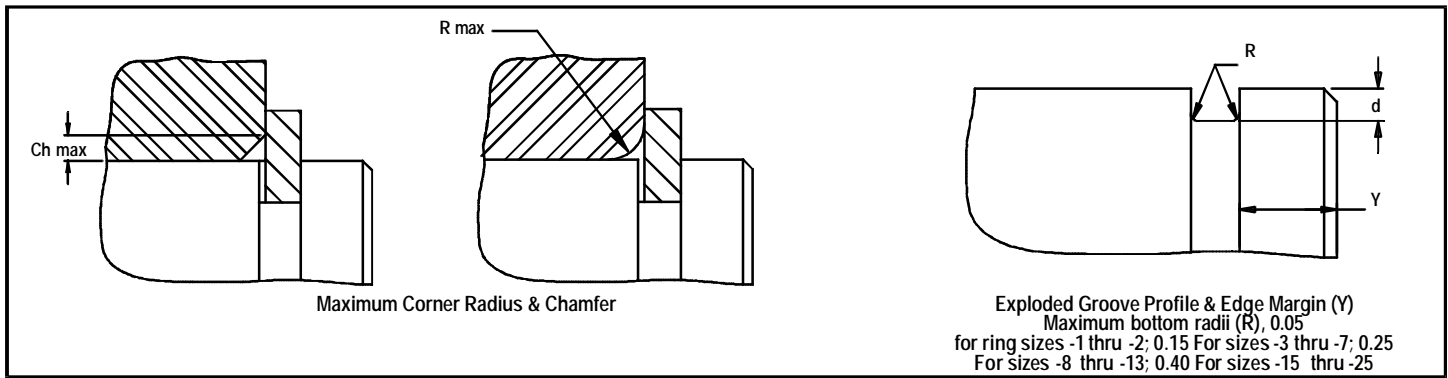

RING NO.	ALLOWABLE CORNER RADII & CHAMFERS		MAX. LOAD w/ R max or Ch max (kN)	EDGE MARGIN		R.P.M. LIMITS Standard Material
	R max	Ch max		P'r	Y	
ME-1*	0.4	0.25	0.06	0.3	40000	
ME-2	0.8	0.50	0.13	0.6	40000	
ME-3	1.1	0.70	0.30	0.7	34000	
ME-4	1.6	1.20	0.70	0.9	31000	
ME-5	1.6	1.20	0.90	1.1	27000	
ME-6	1.6	1.20	1.10	1.2	25000	
ME-7	1.6	1.20	1.20	1.5	23000	
ME-8	1.7	1.30	1.40	1.6	21500	
ME-9	1.7	1.30	3.00	1.8	19500	
ME-10	1.7	1.30	3.40	2.0	18000	
ME-11	1.7	1.30	3.70	2.1	16500	
ME-12	1.9	1.40	4.90	2.4	15000	
ME-13	2.0	1.50	5.40	2.7	13000	
ME-15	2.0	1.50	6.20	3.2	11500	
ME-16	2.0	1.50	6.60	3.5	10000	
ME-18	2.1	1.60	8.70	3.7	9000	
ME-20	2.2	1.70	9.80	4.0	8000	
ME-22	2.2	1.70	10.80	4.6	7000	
ME-25	2.4	1.90	12.20	5.0	5000	

LARGER SIZES MAY BE AVAILABLE UPON REQUEST.

TABLE 1: HARDNESS RANGES-ROTOR CLIP STAINLESS STEEL RINGS (PH 15-7 MO)

RING	SIZE RANGE	SCALE	ROCKWELL HARDNESS
ME	2-3	15N	82.5-86
	4-8	30N	63-69.5
	9-25	C	44-51

TABLE 2: HARDNESS RANGES-ROTOR CLIP BERYLLIUM COPPER RINGS

RING	SIZE RANGE	SCALE	ROCKWELL HARDNESS
ME	1-3	15N	79-82*
	4-9	30N	56.5-68
	10-25	C	37-43

TABLE 3: HARDNESS RANGES-ROTOR CLIP CARBON STEEL RINGS (SAE 1060-1090)

RING	SIZE RANGE	SCALE	ROCKWELL HARDNESS
ME	2-3	15N	85-87
	4-8	30N	67.5-71
	9-25	C	48-52

\* Hardness cannot be checked with any degree of accuracy directly on these rings.