

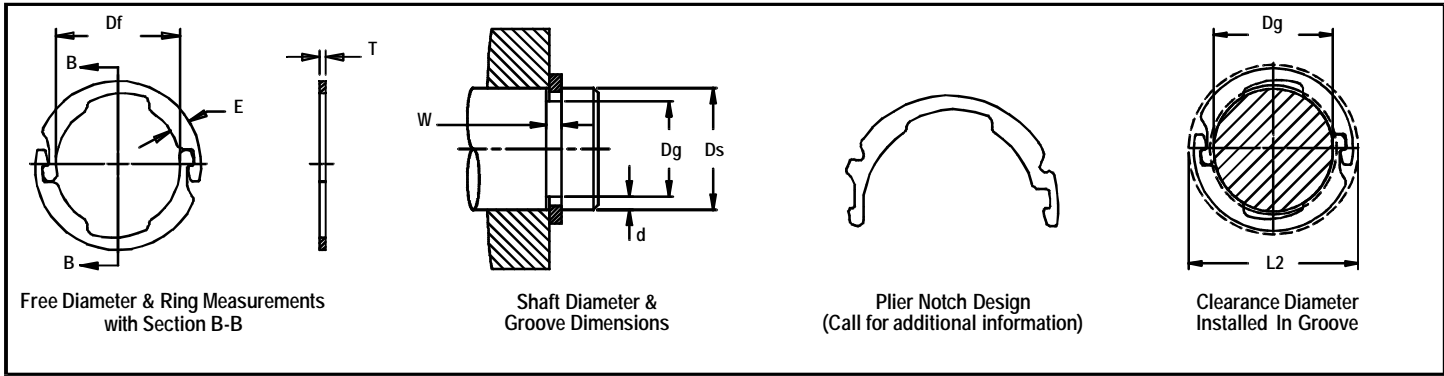

# Rotor Clip LC Retaining Rings

## Radially Assembled, External Retaining Rings

The two halves of this retaining ring interlock and retain assemblies with extremely high rotational speeds.



RING NO.	SHAFT			GROOVE SIZE				RING SIZE & WEIGHT				Clearance Installed in groove	i Thrust Id. (lbs.) Sq. Corner Abutment			
	DIAMETER			DIAMETER	WIDTH	DEPTH	FREE DIAMETER	THICKNESS***		Weight Per 1000 Rings	Ring Safety factor of 3		Groove Safety factor of 2			
	Ds DEC	Ds FRACT	Ds mm	Dg	Tol.	W	Tol.	d	Df					Tol.	T	Tol.
LC-46	.469	15/32	11.9	.419	±.0015	.039		.025	.414		.035		1.36	.640	2030	620
LC-50	.500	1/2	12.7	.464	.004*	.039		.018	.459		.035		1.50	.680	2132	480
LC-59	.594	19/32	15.1	.544		.039	+ .003	.025	.538	±.002	.035		1.74	.766	2538	790
LC-62	.625	5/8	15.9	.575		.039	- .000	.025	.569		.035		1.82	.797	2690	830
LC-66	.669	-	17.0	.599		.046		.035	.593		.042		3.1	.886	3400	1250
LC-75	.750	3/4	19.0	.680	±.002	.046		.035	.673	±.003	.042	±.002	3.5	.967	3806	1400
LC-78	.781	25/32	19.8	.711	*.004	.046		.035	.703		.042		3.6	.998	4009	1450
LC-87	.875	7/8	22.2	.805		.046		.035	.796		.042		3.8	1.092	4466	1600
LC-98	.984	63/64	25.0	.872	±.003	.056		.056	.863		.050		7.3	1.273	5938	2900
LC-98	1.000	1	25.4	.872	*.004	.056		.064	.863		.050		7.3	1.273	5938	3400
LC-112	1.125	1-1/8	28.6	1.013		.056		.056	1.002		.050		7.9	1.42	6801	3350
LC-118	1.188	1-3/16	30.2	1.075	±.003	.056	+ .004	.056	1.064	±.004	.050		8.5	1.48	7207	3500
LC-125	1.250	1-1/4	31.7	1.138	*.005	.056	- .000	.056	1.126		.050		8.9	1.54	7562	3700
LC-137	1.375	1-3/8	34.9	1.263		.056		.056	1.250		.050		9.6	1.67	8323	4100
LC-150	1.500	1-1/2	38.1	1.388		.056		.056	1.374		.050		10.6	1.79	9084	4450
LC-156	1.562	1-9/16	39.7	1.427		.068		.068	1.412		.062		16.4	1.91	11926	5650
LC-162	1.625	1-5/8	41.3	1.489		.068		.068	1.474		.062		17.5	1.97	12434	5850
LC-175	1.750	1-3/4	44.4	1.614	±.005	.068		.068	1.597	±.005	.062	±.003	18.4	2.10	13398	6300
LC-175	1.772	-	45.0	1.614	*.005	.068		.078	1.597		.062		18.4	2.10	13398	7350
LC-187	1.875	1-7/8	47.6	1.739		.068		.068	1.721		.062		20.8	2.22	14312	6800
LC-196	1.969	1-31/32	50.0	1.797		.086		.086	1.779		.078		31.0	2.37	18524	9000
LC-200	2.000	2	50.8	1.828		.086		.086	1.809		.078		31.6	2.40	18778	9150
LC-212	2.125	2-1/8	54.0	1.953	±.005	.086	+ .005	.086	1.933	±.006	.078	±.003	34.2	2.52	19996	9700
LC-212	2.156	2-5/32	54.8	1.953	*.006	.086	- .000	.101	1.933		.078		34.2	2.52	19996	11500
LC-225	2.250	2-1/4	57.1	2.078		.086		.086	2.057		.078		37.3	2.65	21112	10300
LC-237	2.375	2-3/8	60.3	2.203		.086		.086	2.180		.078		38.9	2.77	22330	10800
LC-250	2.500	2-1/2	63.5	2.328		.086		.086	2.304		.078		39.7	2.90	23548	11400
LC-262	2.625	2-5/8	66.7	2.453		.086		.086	2.428		.078		43.9	3.02	24665	12000
LC-275	2.750	2-3/4	69.8	2.544		.103		.103	2.518		.093		63.2	3.25	30653	15000
LC-287	2.875	2-7/8	73.0	2.669	±.006	.103		.103	2.642	±.008	.093		68.4	3.37	32074	15700
LC-300	3.000	3	76.2	2.794	*.006	.103		.103	2.754		.093		70.4	3.50	33495	16400
LC-325	3.250	3-1/4	82.5	3.044		.103		.103	3.013		.093		77.6	3.75	36286	17800
LC-337	3.375	3-3/8	85.7	3.145		.120		.115	3.114		.109		94.0	3.99	44153	20600

\*F.I.M. (FULL INDICATOR MOVEMENT) - MAXIMUM ALLOWABLE DEVIATION OF CONCENTRICITY BETWEEN GROOVE AND SHAFT.  
 † BASED ON HOUSINGS/SHAFTS MADE OF COLD ROLLED STEEL. FOR AN EXPLANATION OF FORMULAS USED TO DERIVE THRUST LOAD AND OTHER PERFORMANCE DATA, CONTACT THE ROTOR CLIP ENGINEERING DEPT.

\*\*\*FOR PLATED RINGS, ADD .002" TO THE LISTED MAXIMUM THICKNESS. MAXIMUM RING THICKNESS WILL BE A MINIMUM OF .0002" LESS THAN THE LISTED GROOVE WIDTH (W) MINIMUM.

For a technical concern,  
Please ask for our Technical Sales Department.

# 1-800-55-ROTOR

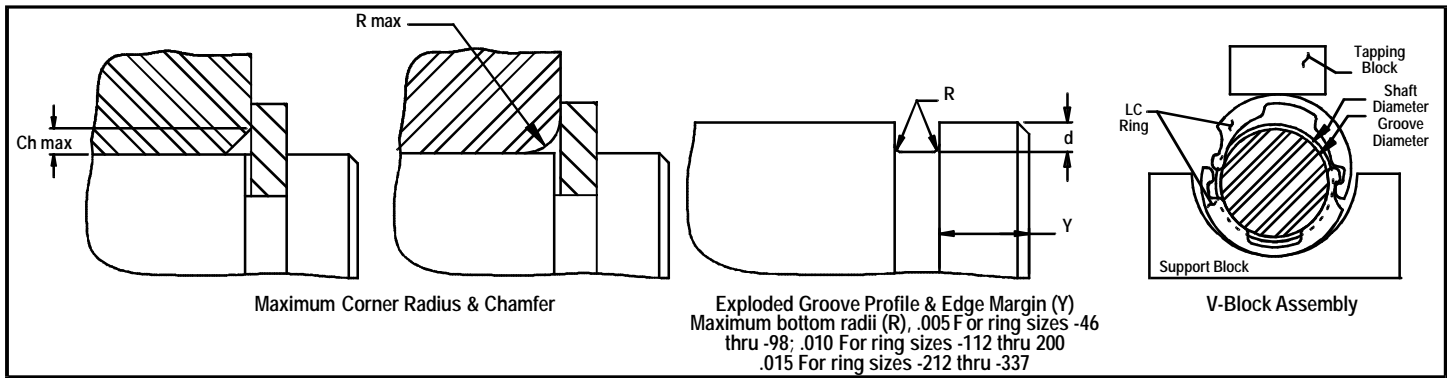

RING NO.	MAXIMUM SECTION		ALLOWABLE CORNER RADII & CHAMFERS		MAX. LOAD W/R max or Ch max (in lbs.)	EDGE MARGIN Y	R.P.M. LIMITS Standard Material
	E	Tol.	R max	Ch max			
LC-46	.105	±.005	.052	.040	610	.075	50000
LC-50	.105		.052	.040	610	.054	50000
LC-59	.105		.052	.040	610	.075	46000
LC-62	.105	±.006	.052	.040	610	.075	45000
LC-66	.135		.065	.050	880	.105	43000
LC-75	.135		.065	.050	880	.105	40000
LC-78	.135		.065	.050	880	.105	39000
LC-87	.135		.065	.050	880	.105	35000
LC-98	.188		.086	.066	1250	.168	31000
LC-98	.188		.081	.062	1250	.192	30000
LC-112	.188		.086	.066	1250	.168	28000
LC-118	.188		.086	.066	1250	.168	27000
LC-125	.188		.086	.066	1250	.168	26000
LC-137	.188	.086	.066	1250	.168	24000	
LC-150	.188	±.007	.086	.066	1250	.168	22000
LC-156	.222		.100	.077	1900	.204	21000
LC-162	.222		.100	.077	1900	.204	20500
LC-175	.222		.100	.077	1900	.204	19000
LC-175	.222		.094	.072	1900	.234	19000
LC-187	.222		.100	.077	1900	.204	17000
LC-196	.262		.114	.088	3050	.258	15500
LC-200	.262		.114	.088	3050	.258	15000
LC-212	.262		.114	.088	3050	.258	14300
LC-212	.262		.104	.080	3050	.303	14300
LC-225	.262	.114	.088	3050	.258	13500	
LC-237	.262	.114	.088	3050	.258	12800	
LC-250	.262	.114	.088	3050	.258	12000	
LC-262	.262	.114	.088	3050	.258	11300	
LC-275	.323	±.008	.143	.110	4300	.309	10500
LC-287	.323		.143	.110	4300	.309	9800
LC-300	.329		.143	.110	4300	.309	9000
LC-325	.325		.144	.111	4300	.309	7500
LC-337	.395		.182	.140	5950	.345	6800

LARGER SIZES MAY BE AVAILABLE UPON REQUEST.

TABLE 1: HARDNESS RANGES-ROTOR CLIP  
STAINLESS STEEL RINGS (PH 15-7 MO)

RING	SIZE RANGE	SCALE	ROCKWELL HARDNESS
LC	all	C	44-51

TABLE 2: HARDNESS RANGES-ROTOR CLIP  
BERYLLIUM COPPER RINGS

RING	SIZE RANGE	SCALE	ROCKWELL HARDNESS
LC	46-62	30N	56.5-62
	66& over	C	37-43

TABLE 3: HARDNESS RANGES-ROTOR CLIP  
CARBON STEEL RINGS (SAE 1060-1090)

RING	SIZE RANGE	SCALE	ROCKWELL HARDNESS
LC	46-62	30N	65.5-70.5
	66& over	C	47-52