

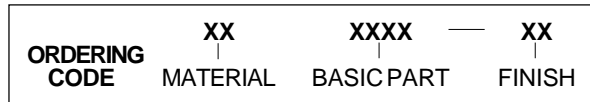

PLAIN THUMB SCREWS

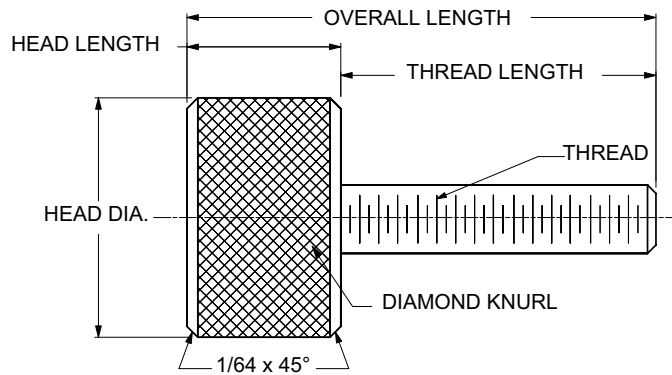

| CODE | FINISH |
|------|----------------------------------|
| 00 | Plain — None |
| 01 | Passivate MIL-F-14072-E300 |
| 61 | Nickel QQ-N-290 CL 1, Type VI KC |

| MATERIAL | CODE |
|-----------------|------|
| BRASS | BR |
| STAINLESS STEEL | SS |
| STEEL | ST |

| BASIC PART NUMBER | THREAD | HEAD DIA +0.020 -0.000 | HEAD LENGTH ±0.015 | OVERALL LENGTH ±0.015 | THREAD LENGTH ±0.010 |
|-------------------|--------|------------------------------|-----------------------|--------------------------|-------------------------|
| 7620 | 4-40 | 5/16 | 3/16 | 1/2 | 5/16 |
| 7621 | 4-40 | 5/16 | 3/16 | 9/16 | 3/8 |
| 7622 | 4-40 | 5/16 | 3/16 | 5/8 | 7/16 |
| 7623 | 4-40 | 5/16 | 3/16 | 11/16 | 1/2 |
| 7624 | 6-32 | 5/16 | 3/16 | 1/2 | 5/16 |
| 7625 | 6-32 | 5/16 | 3/16 | 9/16 | 3/8 |
| 7626 | 6-32 | 5/16 | 3/16 | 5/8 | 7/16 |
| 7627 | 6-32 | 5/16 | 3/16 | 11/16 | 1/2 |
| 7628 | 8-32 | 3/8 | 3/16 | 9/16 | 3/8 |
| 7629 | 8-32 | 3/8 | 3/16 | 5/8 | 7/16 |
| 7630 | 8-32 | 3/8 | 3/16 | 11/16 | 1/2 |
| 7631 | 8-32 | 3/8 | 3/16 | 3/4 | 9/16 |
| 7632 | 8-32 | 3/8 | 3/16 | 13/16 | 5/8 |
| 7633 | 10-32 | 7/16 | 3/16 | 9/16 | 3/8 |
| 7634 | 10-32 | 7/16 | 3/16 | 5/8 | 7/16 |
| 7635 | 10-32 | 7/16 | 3/16 | 11/16 | 1/2 |
| 7636 | 10-32 | 7/16 | 3/16 | 3/4 | 9/16 |
| 7637 | 10-32 | 7/16 | 3/16 | 13/16 | 5/8 |
| 7638 | 1/4-20 | 1/2 | 1/4 | 3/4 | 1/2 |
| 7639 | 1/4-20 | 1/2 | 1/4 | 13/16 | 9/16 |
| 7640 | 1/4-20 | 1/2 | 1/4 | 7/8 | 5/8 |
| 7641 | 1/4-20 | 1/2 | 1/4 | 15/16 | 11/16 |
| 7642 | 1/4-20 | 1/2 | 1/4 | 1 | 3/4 |

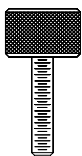

F43