

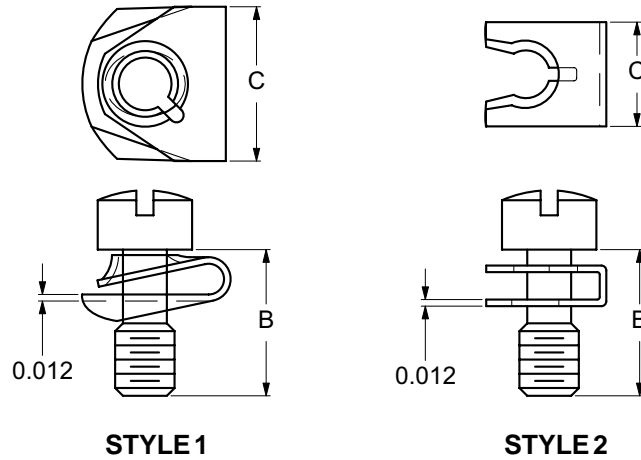

MALE SCREW-LOCK ASSEMBLY ("U" Type)



PART NUMBERS		A STYLE	B LENGTH	C LENGTH	D WIDTH	THREAD	RETAINING CLIP		SCREW	
KIT	BULK						MATERIAL	FINISH	MATERIAL	FINISH
ST9334-36	ST9335-36	1	.26	.25	.28	4-40 UNC-2A	STEEL	ZINC YELLOW	COLD ROLLED STEEL	YELLOW
ST9336-34	ST9337-34	1	.26	.25	.28		STEEL	ZINC CLEAR		ZINC CLEAR
SSST9338-0136	SSST9339-0136	2	.22	.20	.18		STAINLESS STEEL	PASSIVATED	ZINC YELLOW	
SSST9340-0134	SSST9341-0134	2	.22	.20	.18		STAINLESS STEEL	PASSIVATED	ZINC CLEAR	
SS9342-01	SS9343-01	2	.22	.20	.18		STAINLESS STEEL	PASSIVATED	STAINLESS STEEL	PASSIVATED



STYLE 1



STYLE 2

NOTES:

1. Two assemblies are required per connector.
2. Each kit contains 2 retaining clips & 2 screws in a bag.
3. Bulk quantities — each type part is separately packaged.
4. All parts are shipped unassembled.
5. Retaining clips must be assembled onto connector flange with threaded hole (style 1) or narrow slot (style 2) toward wire (cable) side of connector.
6. A 6'' lb. (female) and 4'' lb. (male) maximum assembly torque is recommended for steel screw locks.
7. Male screw locks mate with female screw locks. See pages G7 to G10.
8. All dimensions are for reference only. Tolerances are to manufacturer's standards.