

DOUBLE TUBE CLAMPS

MATERIAL: HD Galv Steel, Chem-Treated G90, Per ASTM A653/A653M
CUSHION: Black Vinyl, 1/32" Thick

DOUBLE TUBE CLAMPS

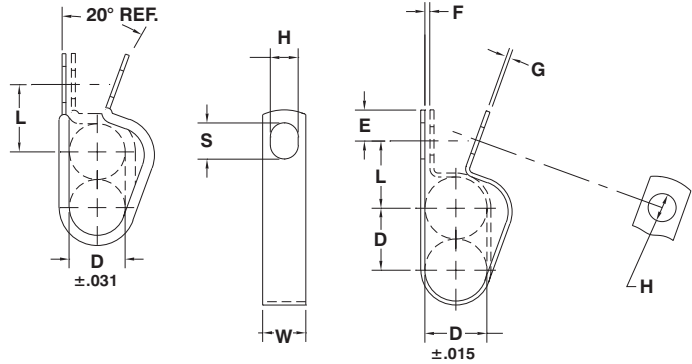

D					H	S	W	E	F	G
Diameter Of Tubes	Part Number	L	Part Number	L	Hole Diameter	Slot Length	Width	Hole Center To End	Gap	Gage
		±.031		±.031	±.005	±.020	±.010	±.015	±.031	See Pg. 40
.187	CDV-0307	.468	CD-0307	.437	.203	.203	.500	.218	.031	.032
	CDV-0309	.500	CD-0309	.468	.281	.375	.500	.312		
	CDV-0311	.562	CD-0311	.531	.343	.437	.625	.375		
	CDV-0313	.625	CD-0313	.593	.406	.500	.750	.437		
.250	CDV-0407	.500	CD-0407	.468	.203	.203	.500	.218	.031	.032
	CDV-0409	.531	CD-0409	.500	.281	.375	.500	.312		
	CDV-0411	.593	CD-0411	.562	.343	.437	.625	.375		
	CDV-0413	.656	CD-0413	.625	.406	.500	.750	.437		
.312	CDV-0509	.562	CD-0509	.531	.281	.375	.500	.312	.031	.032
	CDV-0511	.625	CD-0511	.593	.343	.437	.625	.375		
	CDV-0513	.687	CD-0513	.656	.406	.500	.750	.437		
.375	CDV-0609	.593	CD-0609	.562	.281	.375	.500	.312	.062	.032
	CDV-0611	.656	CD-0611	.625	.343	.437	.625	.375		
	CDV-0613	.718	CD-0613	.687	.406	.500	.750	.437		
	CDV-0615	.781	CD-0615	.750	.468	.562	.875	.500		
	CDV-0617	.843	CD-0617	.812	.531	.625	1.000	.562		
.437	CDV-0709	.625	CD-0709	.593	.281	.375	.500	.312	.062	.032
	CDV-0711	.687	CD-0711	.656	.343	.437	.625	.375		
	CDV-0713	.750	CD-0713	.718	.406	.500	.750	.437		
	CDV-0715	.812	CD-0715	.781	.468	.562	.875	.500		
	CDV-0717	.875	CD-0717	.843	.531	.625	1.000	.562		
.500	CDV-0809	.656	CD-0809	.625	.281	.375	.500	.312	.062	.048
	CDV-0811	.718	CD-0811	.687	.343	.437	.625	.375		
	CDV-0813	.781	CD-0813	.750	.406	.500	.750	.437		
	CDV-0815	.843	CD-0815	.812	.468	.562	.875	.500		
	CDV-0817	.906	CD-0817	.875	.531	.625	1.000	.562		
.562	CDV-0909	.687	CD-0909	.656	.281	.375	.500	.312	.062	.048
	CDV-0911	.750	CD-0911	.718	.343	.437	.625	.375		
	CDV-0913	.812	CD-0913	.781	.406	.500	.750	.437		
	CDV-0915	.875	CD-0915	.843	.468	.562	.875	.500		
	CDV-0917	.937	CD-0917	.906	.531	.625	1.000	.562		

Inspection note: Ends of legs may not line up if clamp is closed around non-rigid tubing or hose. For inspection, close around a hard mandrel.

DOUBLE TUBE CLAMPS

MATERIAL: HD Galv Steel, Chem-Treated G90, Per ASTM A653/A653M

CUSHION: Black Vinyl, 1/32" Thick

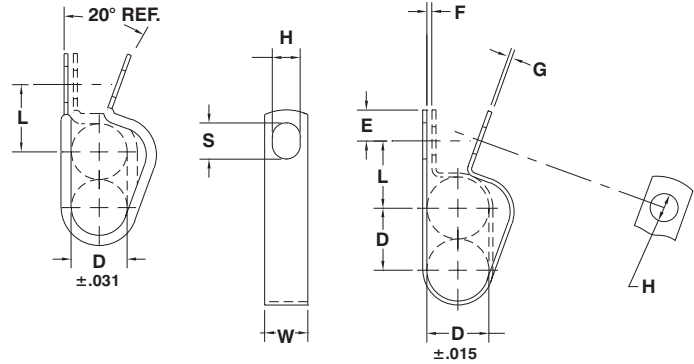

D					H	S	W	E	F	G
Diameter Of Tubes	Part Number	L	Part Number	L	Hole Diameter	Slot Length	Width	Hole Center To End	Gap	Gage
		±.031		±.031	±.005	±.020	±.010	±.015	±.031	See Pg. 40
.625	CDV-1009	.750	CD-1009	.718	.281	.375	.500	.312	.062	.048
	CDV-1011	.781	CD-1011	.750	.343	.437	.625	.375		
	CDV-1013	.843	CD-1013	.812	.406	.500	.750	.437		
	CDV-1015	.906	CD-1015	.875	.468	.562	.875	.500		
	CDV-1017	.968	CD-1017	.937	.531	.625	1.000	.562		
.687	CDV-1111	.812	CD-1111	.781	.343	.437	.625	.375	.062	.048
	CDV-1113	.875	CD-1113	.843	.406	.500	.750	.437		
	CDV-1115	.937	CD-1115	.906	.468	.562	.875	.500		
	CDV-1117	1.000	CD-1117	.968	.531	.625	1.000	.562		
.750	CDV-1211	.843	CD-1211	.812	.343	.437	.625	.375	.062	.048
	CDV-1213	.906	CD-1213	.875	.406	.500	.750	.437		
	CDV-1215	.968	CD-1215	.937	.468	.562	.875	.500		
	CDV-1217	1.031	CD-1217	1.000	.531	.625	1.000	.562		
.812	CDV-1311	.875	CD-1311	.843	.343	.437	.625	.375	.062	.060
	CDV-1313	.937	CD-1313	.906	.406	.500	.750	.437		
	CDV-1315	1.000	CD-1315	.968	.468	.562	.875	.500		
	CDV-1317	1.062	CD-1317	1.031	.531	.625	1.000	.562		
.875	CDV-1411	.906	CD-1411	.875	.343	.437	.625	.375	.062	.060
	CDV-1413	.968	CD-1413	.937	.406	.500	.750	.437		
	CDV-1415	1.031	CD-1415	1.000	.468	.562	.875	.500		
	CDV-1417	1.093	CD-1417	1.062	.531	.625	1.000	.562		
.937	CDV-1511	.937	CD-1511	.906	.343	.437	.625	.375	.062	.060
	CDV-1513	1.000	CD-1513	.968	.406	.500	.750	.437		
	CDV-1515	1.062	CD-1515	1.031	.468	.562	.875	.500		
	CDV-1517	1.125	CD-1517	1.093	.531	.625	1.000	.562		
1.000	CDV-1611	.968	CD-1611	.937	.343	.437	.625	.375	.062	.060
	CDV-1613	1.031	CD-1613	1.000	.406	.500	.750	.437		
	CDV-1615	1.093	CD-1615	1.062	.468	.562	.875	.500		
	CDV-1617	1.156	CD-1617	1.125	.531	.625	1.000	.562		

Inspection note: Ends of legs may not line up if clamp is closed around non-rigid tubing or hose. For inspection, close around a hard mandrel.