

CONTROL CABLE CLIPS For Casing and Bowden Wire

Side Mount

MATERIAL: Spring Steel*
FINISH: Zinc Plate, Bake and Clear Chromate

Figure	Part Number	D Tubing Diameter	A Cable Diameter
1	SW-1206	3/4	3/16 - 7/32
1	SW-1210	3/4	5/16
1	SW-1406	7/8	3/16 - 7/32
1	SW-1412	7/8	3/8
1	SW-1606	1	3/16 - 7/32
1	SW-2006	1-1/4	3/16 - 7/32
2	MW-1408	7/8	1/4

*C-1050 Ann. Spring Steel Heat Treated to Blue Spring Temper.

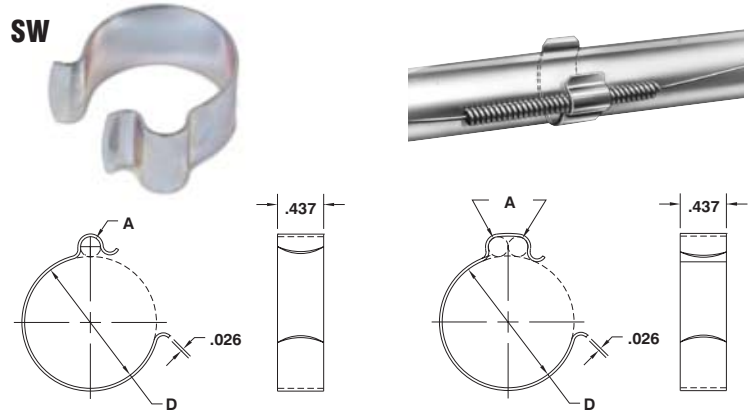

Figure 1 - "SW"

Figure 2 - "MW"

Center Mount

MATERIAL: Spring Steel*
FINISH: Zinc Plate, Bake and Clear Chromate

Figure	Part Number	D Tubing Diameter	A Cable Diameter
3	BW-1206	3/4	3/16 - 7/32
3	BW-1208	3/4	1/4
3	BW-1406	7/8	3/16 - 7/32
3	BW-1408	7/8	1/4
3	BW-1409	7/8	1/4
3	BW-1606	1	3/16 - 7/32
3	BW-1610	1	5/16
3	BW-1810	1-1/8	5/16

*C-1050 Ann. Spring Steel Heat Treated to Blue Spring Temper.

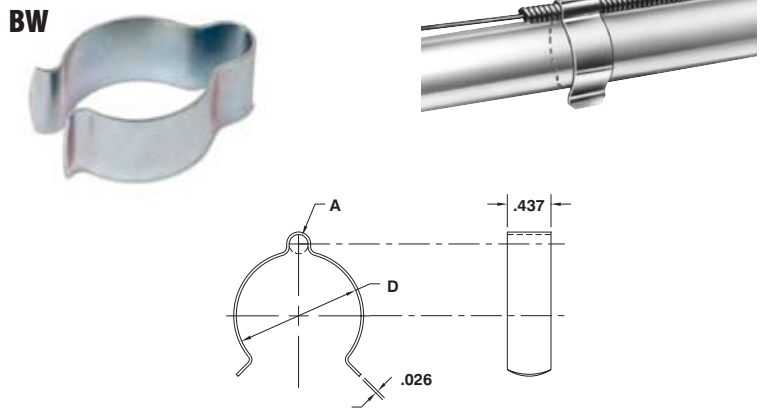

Figure 3 - "BW"

Engine and Deck Mount

MATERIAL: HD Galv Steel, Chem-Treated G90,
 Per ASTM A653/A653M

Part Number	D Cable Diameter	H Diameter Of Holes	L Center To Center	E Hole Center To End
		±.005	±.031	±.015
CE-0613	3/16	.203	.375	.218
CE-0618	3/16	.281	.375	.250
CE-0713	7/32	.203	.375	.218
CE-0718	7/32	.281	.375	.250
CE-0813	1/4	.203	.437	.218
CE-0818	1/4	.281	.437	.250

