

RING NO.	SHAFT DIAMETER			GROOVE SIZE			RING SIZE & WEIGHT				CLEAR. DIA.			THRUST LD. (lbs.)			
	DIAMETER			DIAMETER		Width		Depth	FREE DIAMETER		THICKNESS***		Weight Per 1000 pcs.	Expanded over shaft	Released in groove	Sqr. corner abutment	
	Ds DEC	Ds FRAC	Ds mm	Dg	Tol.	W	Tol.	d	Df	Tol.	T	Tol.				lbs.	L1
SHR-39	.394	-	10.0	.368	+0.01	.039		.013	.362	+0.003	.035		.70	.61	.58	2030	700
SHR-42	.428	-	10.9	.402	-0.02	.039	+0.003	.013	.394	-0.008	.035		.86	.65	.62	2335	800
SHR-47	.473	-	12.0	.444	.002*	.046	-0.000	.015	.435		.042		1.4	.69	.66	3045	1000
SHR-50	.500	1/2	12.7	.468		.056		.016	.460		.050	±0.002	1.6	.75	.72	3959	1100
SHR-59	.591	-	15.0	.555		.056	+0.004	.018	.543		.050		2.2	.86	.83	4568	1500
SHR-62	.625	5/8	15.9	.588		.056	-0.000	.019	.575		.050		2.3	.90	.86	4872	1600
SHR-66	.669	-	17.0	.629		.056		.020	.616	+0.005	.050		2.6	.94	.90	5278	1900
SHR-75	.750	3/4	19.0	.704	+0.001	.086		.023	.689	-0.010	.078		5.6	1.12	1.08	9135	2400
SHR-75	.787	-	20.0	.740	-0.003	.086		.024	.689		.078		5.6	1.16	1.12	9135	2400
SHR-87	.875	7/8	22.2	.821	.002*	.086		.027	.804		.078		7.5	1.25	1.20	10556	3300
SHR-98	.984	63/64	25.0	.925		.086		.030	.906		.078		7.8	1.36	1.30	11673	4000
SHR-98	1.000	1	25.4	.938		.086		.031	.906		.078		7.8	1.37	1.31	11673	4000
SHR-106	1.062	1-1/16	27.0	.998		.103		.032	.978		.093		11.5	1.52	1.46	15225	4800
SHR-112	1.125	1-1/8	28.6	1.059		.103	+0.005	.033	1.036		.093	±0.003	12.5	1.58	1.52	16240	5200
SHR-118	1.181	-	30.0	1.111		.103	-0.000	.035	1.087	+0.010	.093		13.5	1.64	1.57	16748	5600
SHR-118	1.188	1-3/16	30.2	1.111	+0.002	.103		.038	1.087	-0.015	.093		13.5	1.64	1.57	16748	5600
SHR-125	1.250	1-1/4	31.7	1.174	-0.004	.103		.038	1.150		.093		14.9	1.70	1.63	17763	6500
SHR-131	1.312	1-5/16	33.3	1.234	.004*	.103		.039	1.208		.093		16.0	1.77	1.69	18270	7400
SHR-137	1.375	1-3/8	34.9	1.291		.103		.042	1.268		.093		17.8	1.83	1.75	19793	8200
SHR-137	1.378	-	35.0	1.291		.103		.044	1.268		.093		17.8	1.83	1.75	19793	8200
SHR-150	1.500	1-1/2	38.1	1.406		.120		.047	1.380		.109		27.0	2.08	1.98	24868	10000
SHR-156	1.562	1-9/16	39.7	1.468		.120		.047	1.437		.109		31.0	2.14	2.05	26390	10400
SHR-156	1.575	-	40.0	1.480		.120		.048	1.437		.109		31.0	2.15	2.06	26930	10400
SHR-175	1.750	1-3/4	44.4	1.650		.120		.050	1.608		.109		33.4	2.34	2.25	29435	12400
SHR-175	1.772	-	45.0	1.669	+0.003	.120		.052	1.608	+0.013	.109		33.4	2.37	2.27	29435	12400
SHR-193	1.938	1-15/16	49.2	1.826	-0.004	.139		.056	1.782	-0.020	.125	±0.004	48.0	2.58	2.48	37555	15300
SHR-193	1.969	1-31/32	50.0	1.850	.004*	.139	+0.006	.060	1.782		.125		48.0	2.61	2.50	37555	15300
SHR-200	2.000	2	50.8	1.880		.139	-0.000	.060	1.840		.125		50.6	2.64	2.53	38570	17000

\* F.I.M.(FULL INDICATOR MOVEMENT)-MAXIMUM ALLOWABLE DEVIATION OF CONCENTRICITY BETWEEN GROOVE AND SHAFT.  
 † BASED ON HOUSINGS/SHAFTS MADE OF COLD ROLLED STEEL. FOR AN EXPLANATION OF FORMULAS USED TO DERIVE THRUST LOAD AND OTHER PERFORMANCE DATA, CONTACT THE ROTOR CLIP ENGINEERING DEPARTMENT.  
 \*\*\* FOR PLATED RINGS, ADD .002" TO THE LISTED MAXIMUM THICKNESS. MAXIMUM RING THICKNESS WILL BE A MINIMUM OF .0002" LESS THAN THE LISTED GROOVE WIDTH (W) MINIMUM.

For a technical concern,  
Please ask for our Technical Sales Department.

# 1-800-55-ROTOR

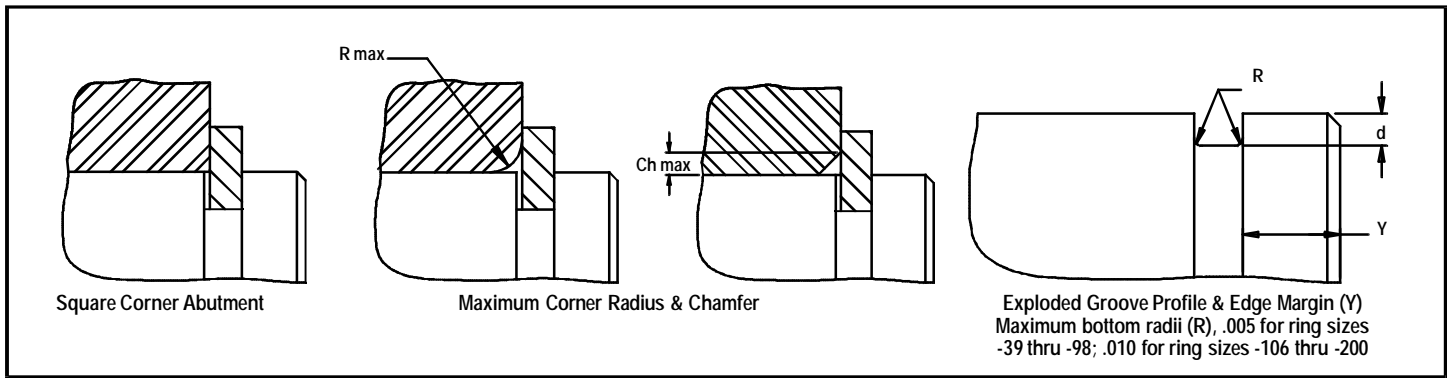

RING NO.	LUG HEIGHT		MAXIMUM SECTION		MINIMUM SECTION		HOLE DIAMETER		GAGING DIA.	ALLOWABLE CORNER RADII & CHAMFERS			MAX LOAD w/ R max or Ch max (in lbs.)	EDGE MARGINS	R.P.M. LIMITS Standard material			
	H	Tol.	S max	Tol.	S min	Tol.	R	Tol.		Gd max	R max	Ch max				P'r	Y	
SHR-39	.101	±.004	.068	±.004	.039	±.004	.042	+.010 -.002	.479	.047	.039	450	.039	80000				
SHR-42	.101		.076		.043		.042		.525	.057	.046	530	.039	72000				
SHR-47	.101		.088		.053		.042		.589	.070	.058	550	.045	69000				
SHR-50	.120		.090		.050		.050		.613	.070	.058	650	.048	65000				
SHR-59	.130	±.005	.102	±.005	.057	±.005	.050	+.015 -.002	.719	.070	.058	750	.054	52500				
SHR-62	.130		.106		.059		.050		.758	.074	.062	750	.057	49000				
SHR-66	.130		.112		.062		.050		.808	.077	.064	900	.060	45000				
SHR-75	.180		.127		.077		.078		.913	.089	.074	2500	.069	40500				
SHR-75	.180	±.006	.127	±.006	.077	±.006	.078	+.015 -.002	.949	.089	.074	2500	.072	38000				
SHR-87	.180		.148		.083		.078		1.056	.100	.083	2500	.081	34000				
SHR-98	.180		.151		.084		.078		1.164	.100	.083	2500	.090	30000				
SHR-98	.180		.151		.084		.078		1.177	.100	.083	2500	.093	30000				
SHR-106	.220	±.005	.161	±.007	.090	±.007	.093	+.015 -.002	1.256	.106	.088	4000	.096	27000				
SHR-112	.220		.169		.095		.093		1.329	.112	.093	4000	.099	26000				
SHR-118	.220		.176		.098		.093		1.391	.112	.093	4000	.105	24000				
SHR-118	.220		.176		.098		.093		1.391	.112	.093	4000	.114	24000				
SHR-125	.220		.185		.103		.093		1.468	.112	.093	4000	.114	23000				
SHR-131	.220		.192		.106		.093		1.538	.128	.107	4000	.117	21500				
SHR-137	.220		.200		.110		.093		1.607	.128	.107	4000	.126	20500				
SHR-137	.220		.200		.110		.093		1.607	.128	.107	4000	.132	20500				
SHR-150	.280		±.008		.218		±.008		.123	±.008	.109	+.015 -.002	1.752	.128	.107	5000	.141	18500
SHR-156	.280				.228				.127		.109		1.829	.128	.107	5000	.141	17000
SHR-156	.280				.228				.127		.109		1.841	.128	.107	5000	.144	17000
SHR-175	.290				.254				.140		.109		2.050	.128	.107	5000	.150	15500
SHR-175	.290	.254		.140	.109	2.069		.128	.107		5000		.156	15500				
SHR-193	.314	±.006		.280	±.006	.154		±.006	.125		+.015 -.002		2.265	.153	.128	6000	.168	14300
SHR-193	.314		.280	.154		.125	2.289		.153	.128		6000	.180	14100				
SHR-200	.314		.290	.160		.125	2.334		.153	.128		6000	.180	14000				

LARGER SIZES MAY BE AVAILABLE UPON REQUEST.

TABLE 1: HARDNESS RANGES-ROTOR CLIP  
STAINLESS STEEL RINGS (PH 15-7 MO)

RING	SIZE RANGE	SCALE	ROCKWELL HARDNESS
SHR	39-42	30N	63-69.5
	47& over	C	44-51

TABLE 2: HARDNESS RANGES-ROTOR CLIP  
BERYLLIUM COPPER RINGS

RING	SIZE RANGE	SCALE	ROCKWELL HARDNESS
SHR	39-42	30N	54-62
	47& over	C	34-43

TABLE 3: HARDNESS RANGES-ROTOR CLIP  
CARBON STEEL RINGS (SAE 1060-1090)

RING	SIZE RANGE	SCALE	ROCKWELL HARDNESS
SHR	39-62	30N	67.5-72
	66& over	C	47-52